

# A new design for simultaneous temperature and strain measurement with spontaneous Raman and Brillouin scattering

Fuchang Chen<sup>a</sup>, Bai Chen<sup>a</sup>, Zunqi Lin<sup>a</sup>

<sup>a</sup>National Laboratory on High Power Laser and Physics, Shanghai Institute of Optics and Fine Mechanics, Chinese

Academy of Sciences , No. 390 Qinghe Road, Jiading, Shanghai, China

## Abstract

We design a new system for simultaneous distributed measurement of temperature and strain based on both spontaneous Raman and Brillouin backscattered signals. The Raman signal can determine the temperature. Although the Brillouin frequency shift is dependent on both temperature and strain of fiber, once the temperature is determined from the Raman signal, the strain can then be computed from the frequency measurement of the Brillouin signal.

**Keywords** : Raman and Brillouin backscatter , temperature , strain , simultaneous measurement

## 1. Introduction

Optical fiber sensor is a newly developing technology with which a system can measure either temperature or strain immediately. Compared with traditional sensors, optical fiber sensor has many merits such as the ability of distributed measurement and the strong capability of anti-electromagnetism etc<sup>[1]</sup>.

In this paper, a new design of simultaneous temperature and strain measurement using Raman and Brillouin scattering is presented. Newson has had similar experiment previously<sup>[2]</sup>. To determine the strain, measure the shift in the Brillouin frequency. However, temperature variations also cause a shift in the Brillouin frequency<sup>[3]</sup>. In other words, the Brillouin frequency shift is dependent on both temperature and strain. Hence , it is difficult to distinguish which factor causes the frequency shift. Based on the existing Brillouin time domain reflectometry system (BOTDR) which was used to measure temperature before, the new design presented in this paper adds specific component to measure temperature using Raman scattering. Therefore, this new system can use the Raman scattering to determine the temperature and use the Brillouin frequency shift to determine the strain meanwhile.

## 2. Principle analysis

### 2.1 Raman backscattering sensing mechanism

When the laser pulse is coupled into the optical fiber, two kinds of scattering photons are generated. One is called Rayleigh scattering photon and it is elastic collision. The other, Brillouin scattering photon and Raman scattering photon, are non-elastic collision. On the time domain, the time interval of back-scattering photons in a local domain on the optical fiber can be measured, then the position of local domain is determined. This is the optical fiber radar technology

called optical time domain reflection (OTDR) [4].

The Rayleigh scattering photon is hardly sensitive to temperature or strain, but the Raman scattering is sensitive to temperature. The anti-Stokes scattered light is much more sensitive than Stokes scattered light. Fortunately, the Raman scattered light is just sensitive to temperature, so we can determine the temperature using only the Raman Stokes and anti-Stokes scattered signals.

The formula [5] to determine temperature is as follows:

$$\frac{1}{T} = \frac{1}{T_0} - \frac{k}{h\Delta\nu} \cdot \ln \frac{\varphi_a(T)/\varphi_s(T)}{\varphi_a(T_0)/\varphi_s(T_0)} \quad (1)$$

$\varphi_a$  : Anti-Stokes Raman back-scattering photon flux;

$\varphi_s$  : Stokes Raman back-scattering photon flux;

$k$  : Boltzmann constant;

$h$  : Planck constant;

$\Delta\nu$  : Raman frequency shift.

Through photo-detector (APD) the Raman scattered light is changed into electrical signal. Afterwards, the electrical signal containing the temperature information of sensing fiber is acquired by a high-speed data acquisition card (DAQ Card) which has a function of calculating the cumulative average values of signal acquired, and then will be run through the computer. The signal to noise ratio has been improved by the ways of time domain average processing through DAQ Card prior to entry in the computer.

## 2.2 Brillouin backscattering sensing mechanism

When light propagates through an optical fiber, the Brillouin frequency shift that is produced is given by:

$$\nu_B = 2nV_A\lambda_L \quad (2)$$

where  $\nu_B$  is the Brillouin frequency shift,  $n$  is the refractive index of the core,  $V_A$  is the acoustic velocity, and  $\lambda_L$  is the free-space wavelength of the forward-propagating light. The acoustic velocity, and hence the Brillouin frequency shift, is dependent on both temperature and strain [7]. That is to say, the Brillouin scattered light is sensitive to both temperature and strain [8] and it's hard to distinguish which factor caused the frequency shift. Therefore the temperature and strain can't be determined simultaneously by just measuring the frequency shift. The formula about the relationship of frequency shift and temperature, strain is as follows [9].

$$\Delta\nu_B = C_\varepsilon\Delta\varepsilon + C_T\Delta T \quad (3)$$

$\Delta\nu_B$  : Brillouin frequency shift;

$C_\varepsilon$  : strain coefficient;

$C_T$  : temperature coefficient.

Through the experiment,  $C_\epsilon$  is 0.05 MHz/ $\mu\epsilon$ ,  $C_T$  is 1.2 MHz/K. The coefficient is close to the one Xiaoyi Bao has obtained by experiments [3]. The formula above has two variations, which can't be determined just using the frequency shift.

### 2.3 The principle of Simultaneous measurement of temperature and strain

Through the analysis above, we can combine BOTDR with the Raman temperature sensor. The temperature is determined by Raman temperature sensor, and the strain is determined by BOTDR.

## 3. System configuration

The experimental configuration for the system [10, 11] is shown in figure 1.

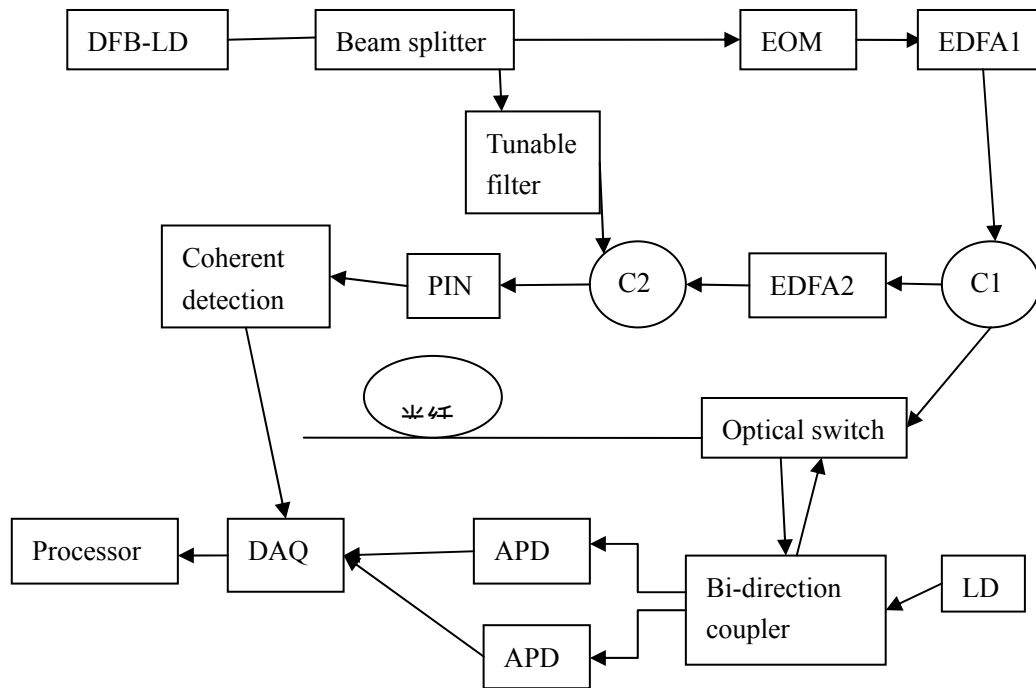

Fig. 1. The design for simultaneous temperature and strain measurement

### 3.1 The Raman component

The 1550nm LD module is used as the Raman temperature system's light source. The pulse light is launched to a

bi-direction coupler. Then it goes into the fiber through the optical switch. The Raman scattered light is generated with the transmission along the fiber of the pulse light. A part of the Raman scattered light goes back through the fiber and enters into the bi-direction coupler, of which the output is divided into two parts, 90% for anti-Stokes light and 10% for Stokes light<sup>[10]</sup> through the optical switch. Then the two different signals go to the photo-detectors (APD) separately. The APDs amplify both of the signals and change them into electrical signals. Then they acquired by the high-speed DAQ Card. After the processing in the computer, the signals are turned to the temperature measured. By now the temperature is determined.

### 3.2 The Brillouin component

We use DFB-LD as the BOTDR's light source. The light is launched to beam splitter. 90% of the light goes to the Electro-optic modulator (EOM), and be turned to pulse light. EDFA1 amplifies the pulse light, then the pulse light passes through the circulator (C1) and injects into the sensing fiber. The Brillouin scattered signal goes back to the circulator (C1), and then goes through EDFA2. After the amplification, it injects into the circulator (C2). Meanwhile, the 10% of the source light passes through the tunable filter, interacts with the backscattered Brillouin signals, then the beat signal is generated. The beat signal passes the circulator (C2), and the photo-detector (PIN) changes the optical signal into electrical signal, after specific processing such as mixing frequency and shifting the frequency down<sup>[12]</sup>, the signal will be sent to the high-speed acquisition card. Finally, with the temperature already processed by the Raman software, the BOTDR software will process the signal and turn it into the strain. It means that the temperature and strain acting on the fiber at the same place can be measured simultaneously.

## 4. Experimental results and analysis

### 4.1 Experimental platform structures

The experimental configuration is shown in figure 2.

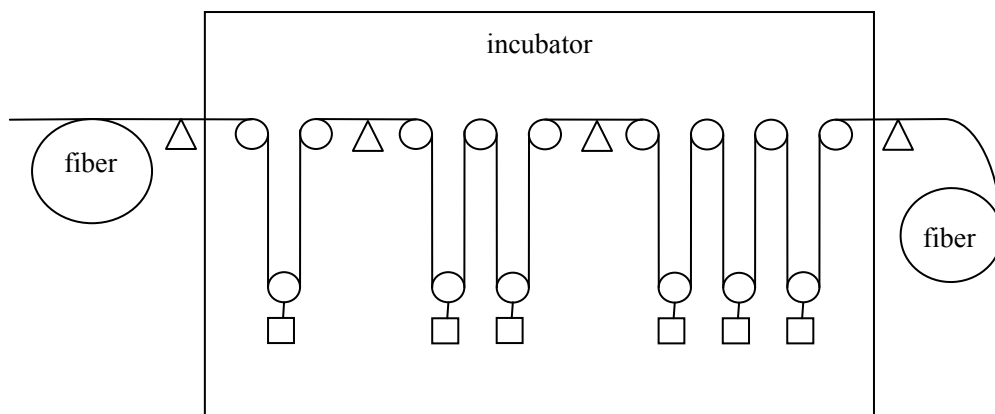

**Fig.2. Layout of the pulleys and sensing fiber in the incubator**

Several pulleys, divided into three sections, wound with fiber, are fixed at specific places in the incubator. The lengths of fiber wound in each section were 3m, 5m, 7m. Movable pulleys of each section can bear different stress [3]. Temperature in the incubator can be set to different desired temperatures and different strains can be obtained by changing weights of different sizes. So the configuration shown in figure 2 can be used to measure temperature and strain of each section simultaneously. There were papers proposing some experimental configurations declared to be able to measure temperature and strain simultaneously. Those configurations turned out to measure temperature and strain at different place rather than at the same place [13]. This is the different point between our experiments.

#### 4.2 Experimental setup and results

In this experiment, the Raman subsystem's light source launched 50ns pulse light, so is the Brillouin subsystem. We use 100MHz high-speed data acquisition card to sample the signal. And the photo-detectors (PIN and APD)'s bandwidth is greater than 30MHz. The heating device of the incubator is turned off at the beginning so that the temperature inside is the same as ambient temperature. And the weights are unloaded so that the fiber is slack. Then run the software to set benchmarks. After the setting of benchmarks, turn on the incubator, set the temperature to 80°C, link each movable to a 150g weight, as is shown in figure 2. Then wait until the temperature stabilized, the results are shown in figure 3 and figure 4.

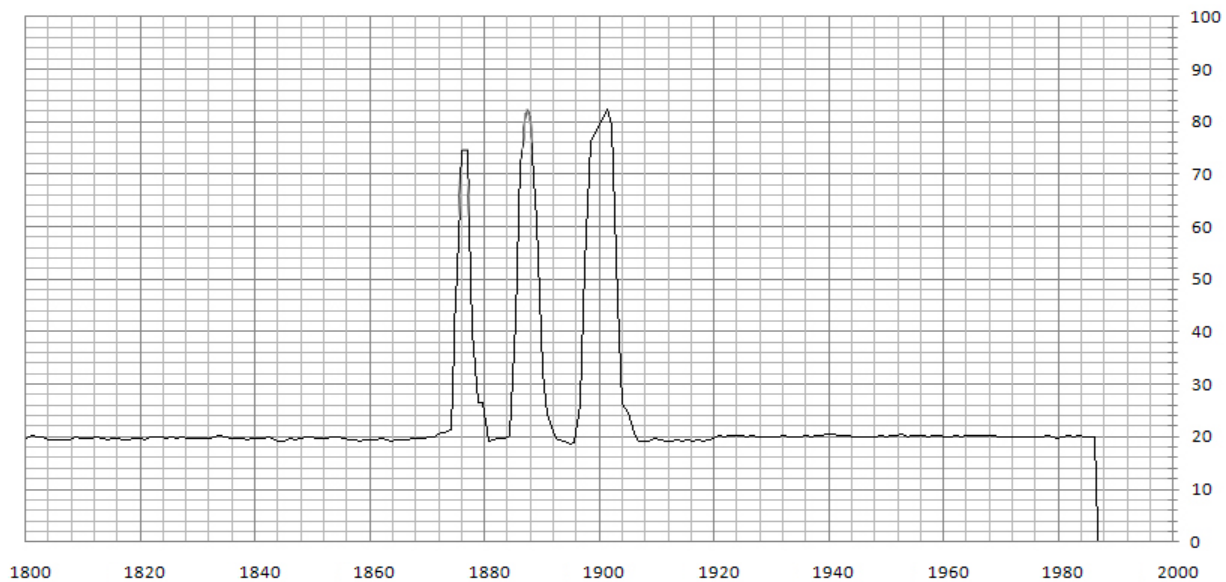
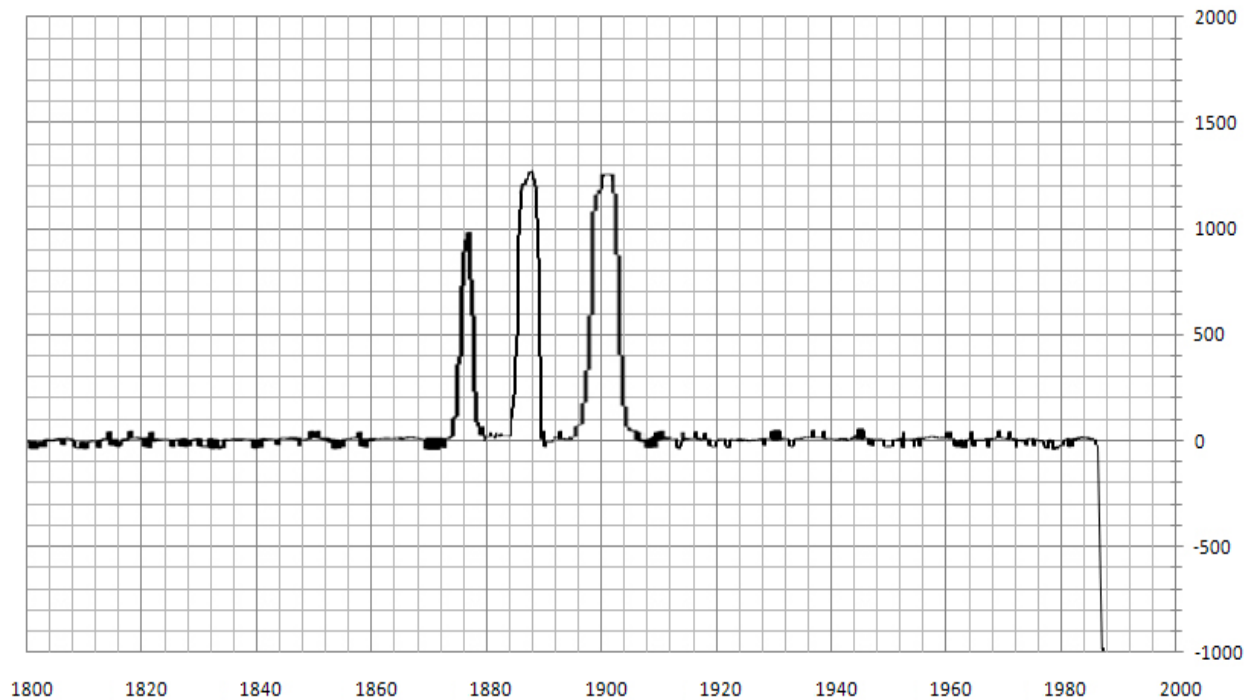

Fig. 3. The temperature measured at 3m, 5m, 7m sensing fiber section



**Fig. 4. The strain measured at 3m, 5m, 7m sensing fiber section**

### 4.3 Experimental analysis

The 3m fiber's temperature measured is lower than the real temperature of the 5m and 7m fiber. The 5m, 7m fiber's temperature measured is about 82.5°C. So the system has a spatial resolution of 5m, temperature accuracy of  $\pm 2.5^{\circ}\text{C}$ . The 5m spatial resolution is consistent with the theory<sup>[14]</sup>.

In figure 4, 5m spatial resolution can also be a conclusion. The temperature accuracy of  $\pm 2.5^{\circ}\text{C}$  will approximately result in a strain accuracy of  $\pm 70 \mu\epsilon$ , coupled with the error of the microwave detection device's processing and the algorithm processing, the strain accuracy will extend to  $\pm 100 \mu\epsilon$ . According to the experiment done by Chen Bai<sup>[15]</sup>, the conclusion of about  $100 \mu\epsilon$  strain per 10g can be attained using the experimental configuration in figure 2. So the theoretical result is that the 150g weight will probably generate  $1500 \mu\epsilon$ . The result we get from the figure 4 is about  $1250 \mu\epsilon$ . It is consistent with the experiments done by Chen Bai.

## 5. Conclusions

A new design for simultaneous temperature and strain measurement with spontaneous Raman and Brillouin scattering is proposed in this paper, and an overview of the sensor measurement principle is also expounded here. Through experiments,

the system has a spatial resolution of 5m, temperature accuracy of  $\pm 2.5^{\circ}\text{C}$  and strain accuracy of  $\pm 100 \mu\epsilon$ . The experimental results have confirmed that the design for simultaneous temperature and strain measurement with Raman and Brillouin scattering is feasibility.

## Reference

1. Zhaoyu Liang, Zhangqing Chen, "Measuring system based on distributive optical fiber temperature sensor", *J. Transd. Technol.* 21(4),33-36(2002)
2. M.N.Alahbabi, Y.T.Cho, and T.P.Newson, "Simultaneous temperature and strain measurement with combined spontaneous Raman and Brillouin scattering", *Opt. Lett.* 30(11), 1276-1278(2005)
3. Jeff Smith, Anthony Brown, Michael DeMerchant, and Xiaoyi Bao, "Simultaneous distributed strain and temperature measurement", *Appl. Opt.* 38(25), 5372-5377(1999)
4. Zhang Zaixuan, Liu Honglin, Wang Jianfeng et al., "Optimum Design of 30km Long Distance Distributed Optical Fiber Raman Temperature Sensor System", *Proc. SPIE* 5634, 182-190(2005)
5. Zhang Zaixuan, Wang Jianfeng, Yu Xiangdong et al., "The Reseach of Raman Type Distributed Optical Fiber Temperature Measuring Method", *J. Optoelectron. Laser.* 12(6), 596-600(2001)
6. Song Muping, Tang Weizhong, Zhou Wen, "Theoretic Analysis for the Temperature Resolution of Distributed Optical-fiber Temperature Sensor Based on Raman Scattering", *Chin. J. Scient. Instrum.* 19(5), 485-488(1998)
7. T.R.Parker, M.Farhadiroushan, V.A.Handerek, and A.J.Rogers, "Temperature and strain dependence of the power level and frequency of spontaneous Brillouin scattering in optical fibers", *Opt. Lett.* 22(11), 787-789(1997)
8. Mohamed N Alahbabi, Yuh Tat Cho and Trevor P Newson, "Long-range distributed temperature and strain optical fiber sensor based on the coherent detection of spontaneous Brillouin scattering with in-line Raman amplification", *Meas. Sci. Technol.* 17, 1082-1090(2006)
9. Sally M Maughan, Huai H Kee and Trevor P Newson, "Simultaneous distributed fiber temperature and strain sensor using microwave coherent detection of spontaneous Brillouin backscatter", *Meas. Sci. Technol.* 12, 834-842(2001)
10. Zhao Hongzhi, Li Naiji, Zhao Dazun, "Improved Extracting Scheme of Backscatterd Raman in Distributed Fbier Temperature Sensors", *Opt. Technol.* 1, 23-24(1997)
11. Kaoru Shimizu, Tsuneo Horiguchi, Yahei Koyamada, and Toshio Kurashima, "Coherent self-heterodyne detection of spontaneously Brillouin-scatterd light waves in a single-mode fiber", *Opt. Lett.* 18(3), 185-187(1993)
12. Mohamed N Alahbabi, Nicholas P Lawrence, Yuh T Cho and Trevor P Newson, "High spatial resolution microwave detection system for Brillouin-based distributed temperature and strain sensors", *Meas. Sci. Technol.* 15, 1539-1543(2004)
13. Huai H. Kee, Gareth P. Lees, and Trevor P. Newson, "All-fiber system for simultaneous interrogation of distributed strain and temperature sensing by spontaneous Brillouin scattering", *Opt. Lett.* 25(10), 695-697(2000)
14. Liu Yan, Zou Jian, Huang Shanglian, "Theoretic Analysis For Determining The Resolution Of Distributed Optical Fiber Temperature Sensing System", *Acta Photonica Sinica.* 25(7), 635-639(1996)
15. Chen Bai, lpbchen12@hotmail.com